



# SR27

Automation Grade	<i>SEMI</i>	<i>Fully</i>	Use Intensity	<i>Low</i>	<i>MEDIUM</i>	<i>High</i>
Format Setting	<i>Manual</i>	<i>AUTOMATIC</i>	Box Dimension	<i>Small</i>	<i>MEDIUM</i>	<i>LARGE</i>

## DATASHEET

SAFE • SUSTAINABLE • STRONG

## Semi-Automatic Case Sealer

The **SR27** is a new semi-automatic case sealing machine designed and engineered by SIAT specifically for large random sized boxes. SR27 is the ideal case sealing machine for a variety of industries like E-commerce, Logistics, Electronics and Tissue.

### KEY FEATURES

- ✓ **Practical** - Seals upper & lower flaps of cardboard cases or cartons
- ✓ **Added Protection** - Lockable electric isolation switch
- ✓ **Taping Heads** - Available with K11 or K12 taping heads
- ✓ **Faster** - 30 m/min belt conveyor speed option available
- ✓ **Ecological** - energy saving option available
- ✓ **Quality Build** - Best-In-Class components with SIEMENS electrics and FESTO pneumatic components
- ✓ **New feature** - Top taping head removable
- ✓ **Improved Design** - Quick release Taping Heads (Top & Bottom – No tools required)
- ✓ **CE compliant** - Engineered and produced in Italy according to EU safety standards

### MACHINE DIMENSIONS

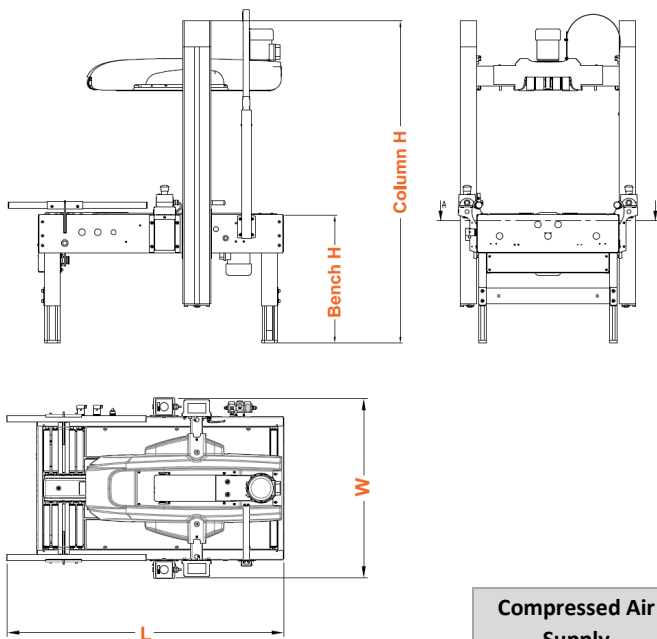

Compressed Air Supply	
Max. 6 bar	
NL/Cycle	9

Machine Dimensions		
	Min (mm)	Max (mm)
H Column	1.465	1.805
H Bench	485	825
W	910	910
W Bench	720	720
L	1.400	1.400

Standard Power Supply	
380/415V_50HZ_3PH+N+PE	
220/230V 50Hz 1PH+N+PE	
Amps	1,08
Power kW	0,26



## DATASHEET

### Technical Data

Belt position	Top + Bottom
Box Size	Medium + Large
Min / Max box weight	0.5 - 32 kg
Default Taping Head	K12 for 3" = 75 mm
Alternative Taping Heads	K11 for 2" = 50 mm
Power Consumption (std.)	0,26 kw
Air Consumption (NL/Cycle)	9
Operator Side	Left (std.) / Right
Tape width (mm)	75 (std.) / 50
Tape Leg (mm)	70 (std.) / 50 / 30
Ingress Protection Code	IP54
Ambient Operating Temperature	+5° / +40° C
Maximum level of noise	Depending on tape quality

### Features

Removable Top Taping-Head	•
Removable Bottom Taping-Head	•
Adjustable Tape Leg	•
Pre-Installed & Easy-To-Mount	•
Adjustable Tape Contact Pressure	•
Autom. Box Format Setting	•
Flap Folding Function	-
Belt Speed Selection	-
Fully Automatic Operation	-
SIAT Taping-Logic on board	-

### MORE MACHINE DIMENSIONS

Length x Width	1.400 x 910
Workbench Width	720
Height H (std. legs)	1.465 – 1.805
Height H1 (std. legs + wheels AS77)	1.575 – 1.915
Height H2 (opt. legs AS80)	1.625 – 1.960
Height H3 (opt. legs AS80 + wheels AS77)	1.735 – 2.070
Workbench Height Z (std. legs)	485 – 825
Workbench Height Z1 (std. legs + wheels AS77)	595 – 935
Workbench Height Z2 (opt. legs AS80)	645 – 980
Workbench Height Z3 (opt. legs AS80 + wheels AS77)	755 – 1.090

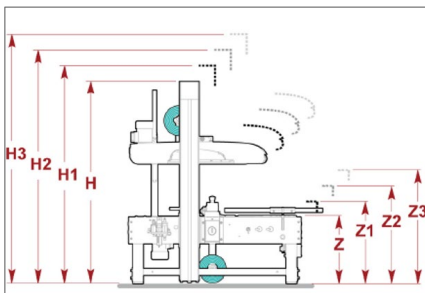

### SPECIAL VERSIONS

Special Versions according to individual application and safety requirements are possible on request.

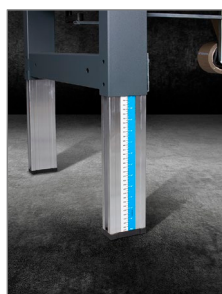
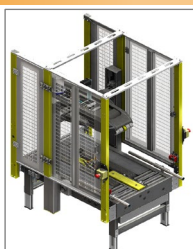

### BOX DIMENSIONS & PRODUCTIVITY

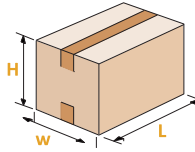

Box Dimensions	L (mm)	W (mm)	H (mm)
Min.	150	170	100*
Max.	∞	650	650

\* 100 mm high box manageable with 50 mm tape leg  
120 mm high box manageable with 70 mm tape leg

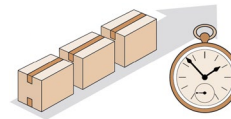

Max. production capacity:  
**Up to 650\* BPH**

\*Based on the shortest processible box length and provided an optimum continuous box infeed by the operator.

### PROCESSABLE TAPES

Base Material	PVC / OPP / PET / Paper*
Adhesive Type	Solvent / Hot Melt / Acrylic
Special Tape	Filament-Tape** / Safety-Seal-Tape***

\*with limitations \*\*special tape cutting blade required \*\*\*need of a test might be necessary

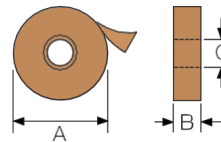

K11R / K12R	
A	Max. 410 mm
B	50 / 75 mm
C	76 mm

### BOX REQUIREMENTS

Quality result of the taped box depends on the general box quality and dimensional accuracy, as well as the quality of tape used.

Box Types: FEFCO 0201 – RSC  
*[other types may be possible as well]*

Adverse Impact Factors	Underfilling	Overfilling	Weak Boxes

### OPTIONS & ACCESSORIES

- Operation side "Right" (std. "Left")
- Special cutting blades filament-tape
- Taping Head for 50mm width
- Power Supply 220/230V – 50hz – 1ph
- Higher Legs
- Casters / Wheels
- Fix / Extendable Roller Conveyors
- Safety fences
- 30 m/min belt speed (std. 22)
- Energy Saving Kit
- End/Break Tape Device

### MORE DETAILS

Videos and further information can be found on our website or SIAT Youtube channel.

