

DRIVE BELTS	AUTOMATION GRADE	BOX FORMAT	FORMAT SETTING	SEALING TECHNOLOGY
SIDE	SEMI-AUTOMATIC	RANDOM	AUTOMATIC	PSA TAPES

# NASTRO-SB R

## SEMI-AUTO RANDOM SIZE

### CASE SEALER

Nastro-SB R is a semi-automatic case sealing machine with double side drive belts, designed and engineered by SIAT to seal with adhesive tapes both upper and lower sides of random size boxes with automatic adjustment, from small to very big dimensions. This model incorporates an advanced Logic, providing full diagnostics, production control and machine parameters through a dedicated Control Panel.

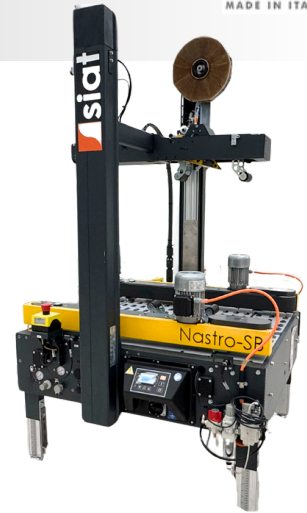

#### KEY BENEFITS

##### AUTOMATIC CASE ADJUSTING

Automatic box adjustment with simultaneous upper & lower flaps sealing to avoid continuous changeover on random boxes production runs, reaching up to 15 box per minute

##### THE POWER OF FLEXIBILITY

Available in different platform sizes and configurations to be able to perfectly process a huge variety of box dimension, covering the market needs.

##### PERFECT BOX SEALING

Dual 75mm side drive belts with the full series of SIAT K taping units available to be installed, from 25 to 75mm width

##### SMART & EFFECTIVE

Production data collection, alarm diagnostics and consumables management to upgrade the control of the end-of-line processes, even from remote

##### SAFETY FIRST

Pinch points eliminated, central or lateral double emergency buttons, lockable electrical switch and CE compliance to guarantee ergonomic and safe operations

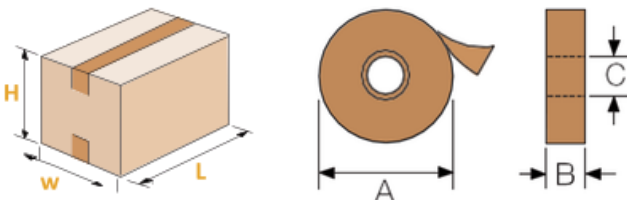

R5 - Machine Weight (kg)	250
R6 - Machine Weight (kg)	260
R8 - Machine Weight (kg)	280

#### SPECIFICATIONS

##### Boxes

	Standard Box Version	Low Box Version
Nastro-SB R5		
Box Min (mm) LxWxH	140 x 150 x 90*	140 x 80 **x 60**
Box Max (mm) LxWxH	∞ x 500 x 500	∞ x 500 x 500
Nastro-SB R6		
Box Min (mm) LxWxH	140 x 150 x 90*	140 x 80 **x 60**
Box Max (mm) LxWxH	∞ x 650 x 650	∞ x 650 x 650
Nastro-SB R8		
Box Min (mm) LxWxH	140 x 150 x 90*	140 x 80 **x 60**
Box Max (mm) LxWxH	∞ x 800 x 800	∞ x 800 x 800

Box Type	RSC, HSC, FEFCO 0200/0201
Flute Type	B-C-E
Min-Max Box Weight (kg)	0,5-32
* 90 with 30mm leg, 100 with 50mm leg, 120 with 70mm leg	
** Considering the smallest unit in displacement configuration	

##### Machine

Productivity up to (bpm)	15
Based on the shortest processible box length, operator speed, box and tape quality	
Belt Speed (m/min)	26 - 35 (variable)
Operator side	Left - Right
(B) Taping Units	K25 (1"/25mm) - K38 (1,5"/38MM) K11 (2"/50mm) - K12 (3"/75mm)
Tape Legs (mm)	30 - 50 - 70
Processable Tapes	PVC / OPP / PET / Paper
(A) Tape Reel Max DIA (mm)	410
(C) Inner Tape Core (mm)	76
Air Consumption (NI/Cycle)	(R5)9 - (R6)12 - (R8)15
Workbench height (mm)	from 540 to 800
Power Supply	400V 50/60Hz 3PH+N+PE 220/240V 50/60Hz 1PH+N+PE
Pneumatic Supply (bar)	5,5 - 7
Installed Power (kW)	0,51
Power Absorption (Amps)	3,4
R5 - Machine Dimensions LxWxH (mm)	1.100 x 990 x 1.350-1.610
R6 - Machine Dimensions LxWxH (mm)	1.100 x 1.150 x 1.515-1.775
R8 - Machine Dimensions LxWxH (mm)	1.100 x 1.395 x 1.835-2.095 (with fences)



## KEY FEATURES

### Automatic Box Adjustment



Automatic height adjustment and side drive belts by pneumatic cylinders to adapt on random size boxes to overcome downtimes of manual setting. Both cycle start from Top and Bottom are available

### Best-in-class Taping Unit



Equipped with SIAT K Taping Units, a market benchmark which offers:

- Smooth and consistent tape application
- Fast reel change and threading with plug&play system

### Scale Up for Big Boxes

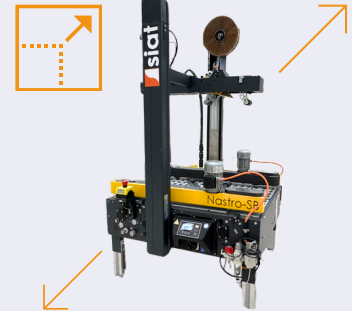

Different set up are available to cover major market needs in terms of box dimension, from 500 up to 800mm.

### Logic On Board



Dedicated Logic to bring box sealing to a next level: parameters setting, box counting, tape consumption, alarms, process failures, cycle detection are only some of the available features.

### Down to Small Boxes

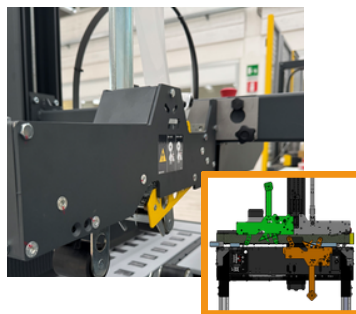

Low Boxes Version with displaceable Integrated taping units can enhance the limits allowing to process very small and very narrow boxes

### Remote Monitoring System



Selecting one of the SIAT Remote Service Packages, it is possible to have real-time monitoring of the information embedded in the Logic from multiple devices

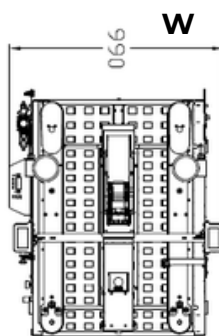
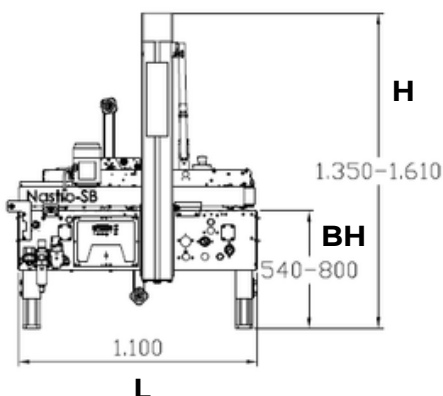

## OPTIONALS

Safety Fences
Energy Saving Mode
Prolonged Motorization
Wheels <sup>1</sup>
Higher Legs <sup>2</sup>
Lower Legs <sup>3</sup>
Conveyors: <b>GTL- GTR</b> (extendable conveyors), <b>RG</b> (roller conveyor)
<sup>1</sup> Workbench height becoming 650 - 910
<sup>2</sup> Workbench height becoming 760 - 1020
<sup>3</sup> Workbench height becoming 440 - 700

IoT Optirun System
End/Brake Tape Device
Pneumatic Taping Unit VENTO 50-75

